

REVISIONS			
REV	DESCRIPTION	DATE	APPROVED
--	--	--	--

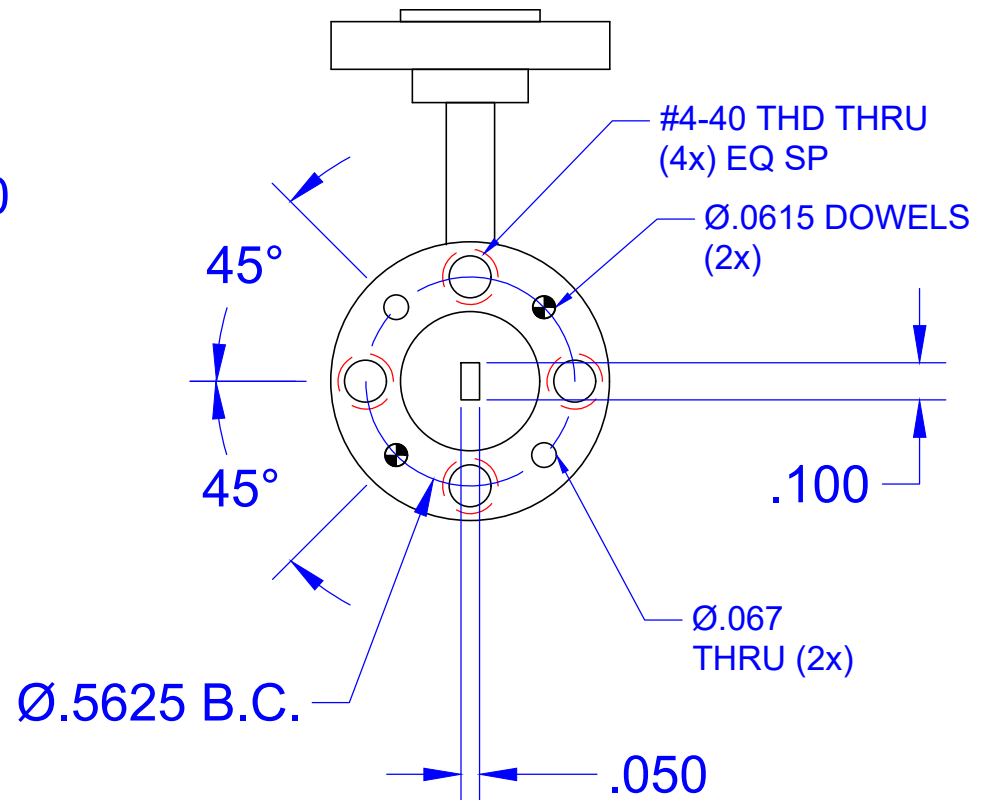
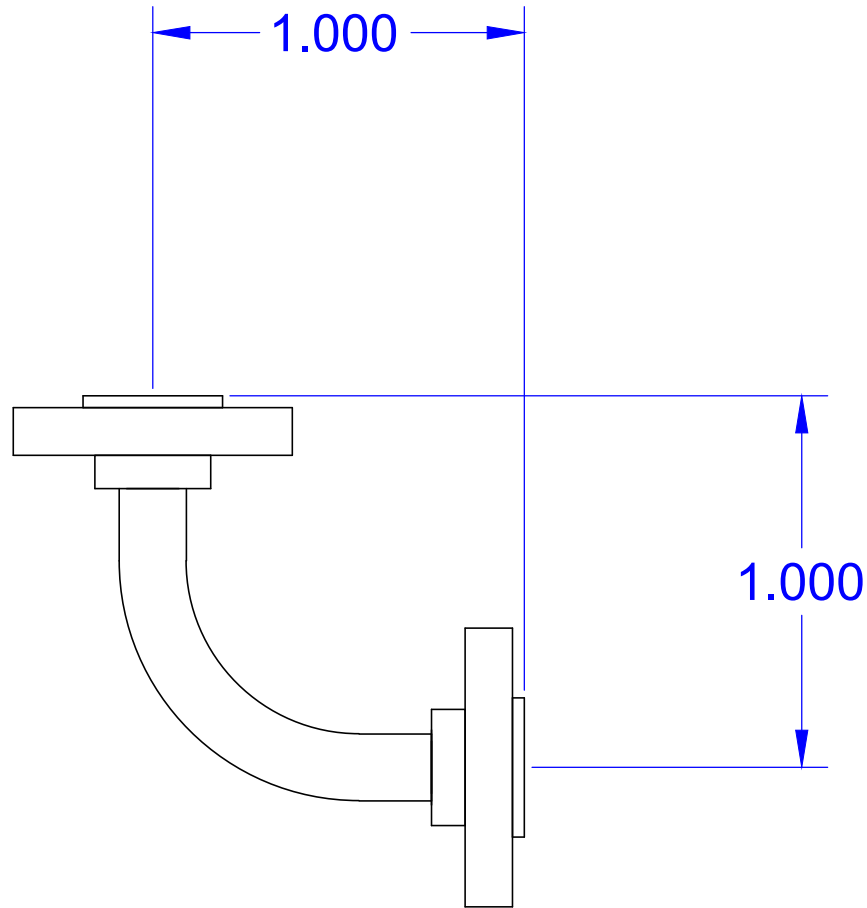

UNLESS OTHERWISE SPECIFIED ALL SURFACES $\sqrt{32}$	
DIMENSIONS ARE IN INCHES TOLERANCES ARE: DECIMALS: .1234 +/- .0005 .123 +/- .005 .12 +/- .01 ANGLES: +/- .5 DEGREES	
ALL THREADS TO BE 2A OR 2B	
REF DWG# --	ORIGINAL DWG# 20164

 THIRD ANGLE PROJECTION	
DRAFTING: K.S.	
APPROVED: M.S.	
DATE: 4/19/2016	
SHEET NO. 1	OF 1

Mi-Wave Millimeter Products Inc.	
TITLE <b>670W/387 H PLANE BEND OUTLINE</b>	
SIZE <b>A</b>	DWG NO <b>22980</b>